

Hydro Jet™ Series Jet Assemblies

SPECIFICATIONS:

Output : 13 GPM, 12 psi, 3/8" Nozzle
1.5 m³/h @ 7m H₂O

Hole Size: Use 2 3/8" hole saw

Options: Wrench 30-3801W
Hand Held 16-5303
Nozzle 10-4707
Orifice 30-4104PVC

Stacked Jet Assemblies

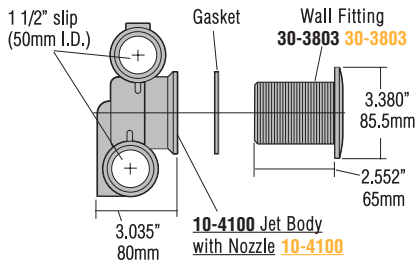
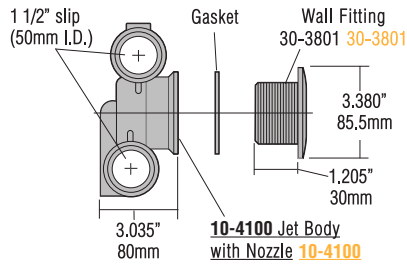

SPECIFICATIONS:

Output : 13 GPM, 12 psi, 1/2" Nozzle
Pipe Size: 1 1/2" PVC

Options: Wall Fitting Assembly 50-3420
Hand Held 16-5303

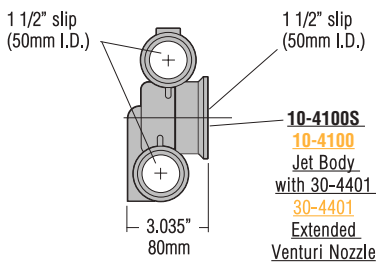

SPECIFICATIONS:

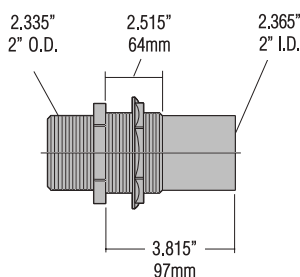

Hydro Jet™ 1 1/4" Fitting Thread Length

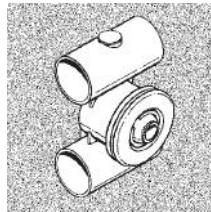

10-5100 includes: 10-4100 Stacked Jet Assembly & 50-3500 Wall Fitting Assembly

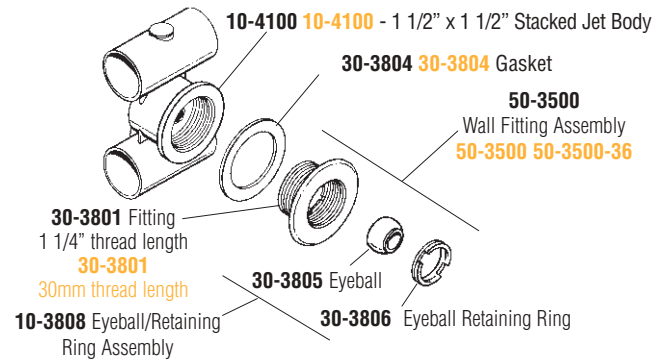

Hydro Jet™ 2 1/2" Fitting Thread Length

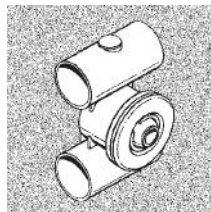

10-5300 includes: 10-4100 Stacked Jet Assembly & 10-3600 Wall Fitting Assembly

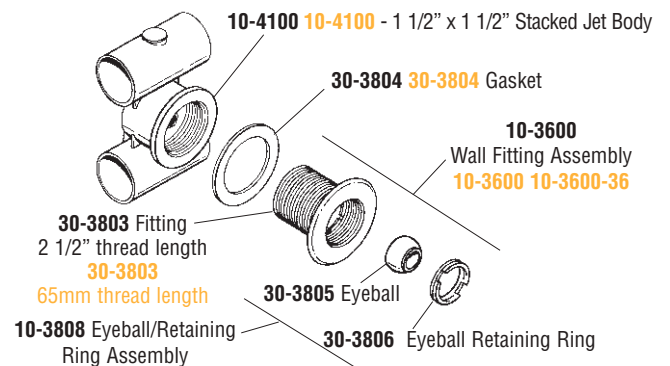

Hydro Jet™ For 1 1/2" PVC Pipe Extension

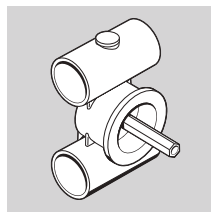

10-4100S includes: 30-4401 Extended Venturi Nozzle (Wall Fitting not included) 10-4100

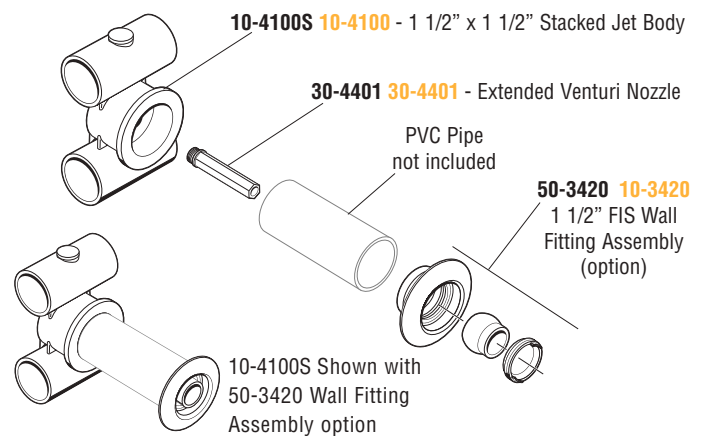

Hydro Jet™ Extension - For Gunite / Hot Mop

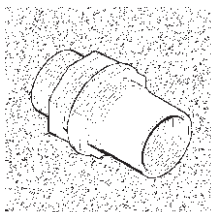

10-4400 includes: Extension Body, and Extended Nozzle (30-4401) 10-4400

